

# AudioMaster® Public Address 2-Watt Re-Entrant Speaker

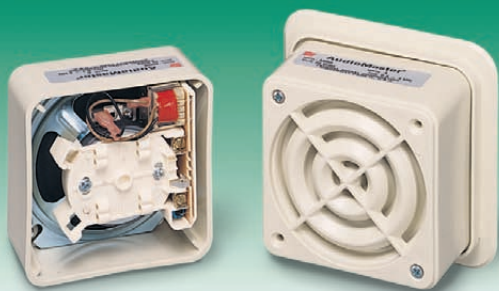

Model AM50

## PUBLIC ADDRESS FOR INDUSTRIAL ENVIRONMENTS

- Transformer coupled
- 25 or 70Vrms
- 2-watts
- Several mounting options
- Re-entrant horn design
- Pre-assembled
- Type 3R with WB Box
- AM50 is UL Fire Listed
- UL 1480 and CSFM Approved

The Federal Signal Model AM50 is a compact, two-watt, transformer coupled speaker for use in public address or paging applications. The unique design of this four-inch square speaker centers around the short, folded, re-entrant horn that is interposed between the diaphragm and the surrounding space. The beige, thermoplastic, flame-retardant housing provides greater efficiency and frequency response while blending easily into commercial and industrial spaces.

Power handling for the AM50 is two watts with transformer taps of 2, 1, 1/2, and 1/4. A moveable contact is used to select the power output. The AM50 comes factory preset in the 1/4 watt position. Two models of the speaker are available for use in 25Vrms and 70Vrms distributed systems. This speaker is supplied with wiring terminals and strain relief for inbound and outbound speaker wiring.

The AM50 is designed primarily for wall mounting and includes a trim ring for adapting to any standard four-inch square or weatherproof back box. This speaker is Underwriters Laboratories Listed for "Fire Protective Signaling Use" and California State Fire Marshall approved.

Model	Power Handling	Frequency Response	Transformer	Power Taps	Beam Width	Decibels @	
						10'	1m
AM50	2-watt	140Hz - 10KHz	25/70Vrms	2,1,1/2,1/4	58°	87	97



## PUBLIC ADDRESS SPEAKER (AM50)

### MOUNTING OPTIONS

AM50 with Trim Plate  
(included) and  
NBL Knock-Out Box

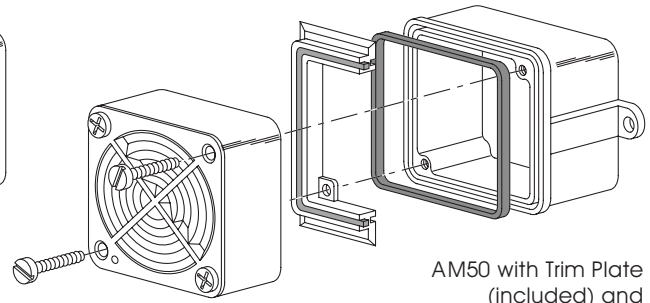
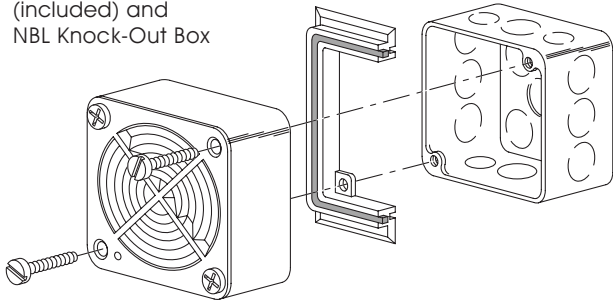

AM50 with Trim Plate  
(included) and  
WB Back Box

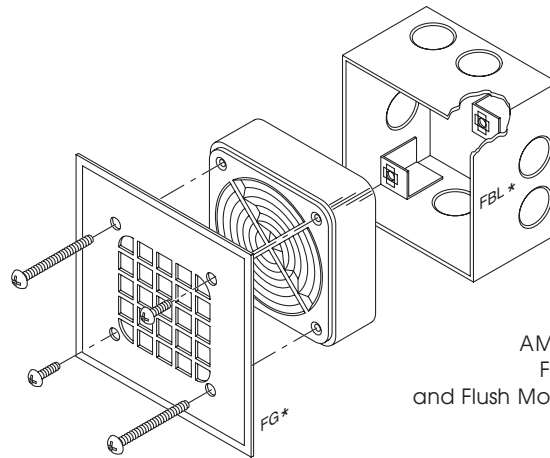

AM50 with  
FG Grille  
and Flush Mount Box

### SPECIFICATIONS

Operating Temperature:	-40°F to 151°F	-40°C to 66°C
Net Weight::	1.4 lbs.	0.64 kg
Shipping Weight::	1.75 lbs.	1.3 kg
Height::	5.5"	137.9 mm
Width:	5.5"	137.9 mm
Depth:	2.5"	63.5 mm

### HOW TO ORDER

- Specify model number
- Specify options:  
Weatherproof Back Box (WB)  
Grille (FG)  
4" Electrical Box (NBL)  
Flush Mount Back Box (FBL)
- Please refer to Model Number Index  
AM50 beginning on page 380